

SPECIFICATIONS

Model: TFT-0108

Confirm by consumer:

--

	Singnature	Date
Engineer of design		
Engineer of frame		
Engineer of quality		
Auditing		

CONTENTS

	<u>Page No.</u>
1. General Description:	4
2. General Feature:	4
3. Block diagram	6
4. Interface signals	6
5. Electrical characteristics	7
6. Absolute maximum rating	7
7. Timing Characteristics	8
8. Electro-Optical characteristics	10
9. Application circuit	12
10. Initial code	12
11. Reliability test	13
12. Quality Guaranty	14
13. General Precautions for touch panel	19
14. Other agreement	21

Specification

1. General Description:

The TFT-0108 model is a-si active matrix TFT display module without Touch panel. This module has 4.3 inch diagonally measured active area with 480 Horizontal by 272 vertical pixel array and this module can display 262K color.

2. General Feature:

Item	Contents	Unit
LCD Type	TFT transmissive, Normally white	/
Viewing direction	6:00	O'clock
Outline dimensions	105.3(W)x 67.0(L)x2.9(T)	mm
Active area	95.04(W)x 53.856(L)	mm
Number of Pixels	480x (R.G.B.) x 272	Dot
Driver IC	OTA5180	/
Colors	262K	/
Backlight type	LED	/
Pixel Pitch (mm)	0.198(H)x0.198(V)	/
Interface Type	16bit paralle	/
Surface treatment	Antiglare	

3. Block diagram

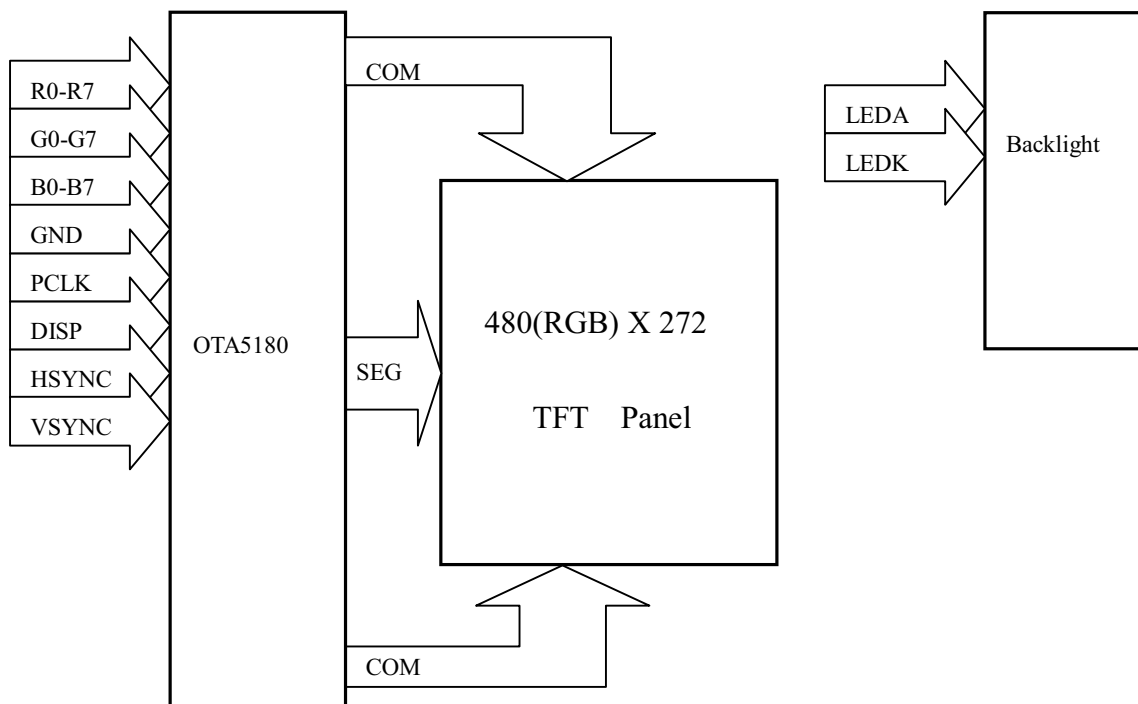

Customer Approved/Data:

1 2 3 4 5 6

Rev.	AMENDMENT	DATE

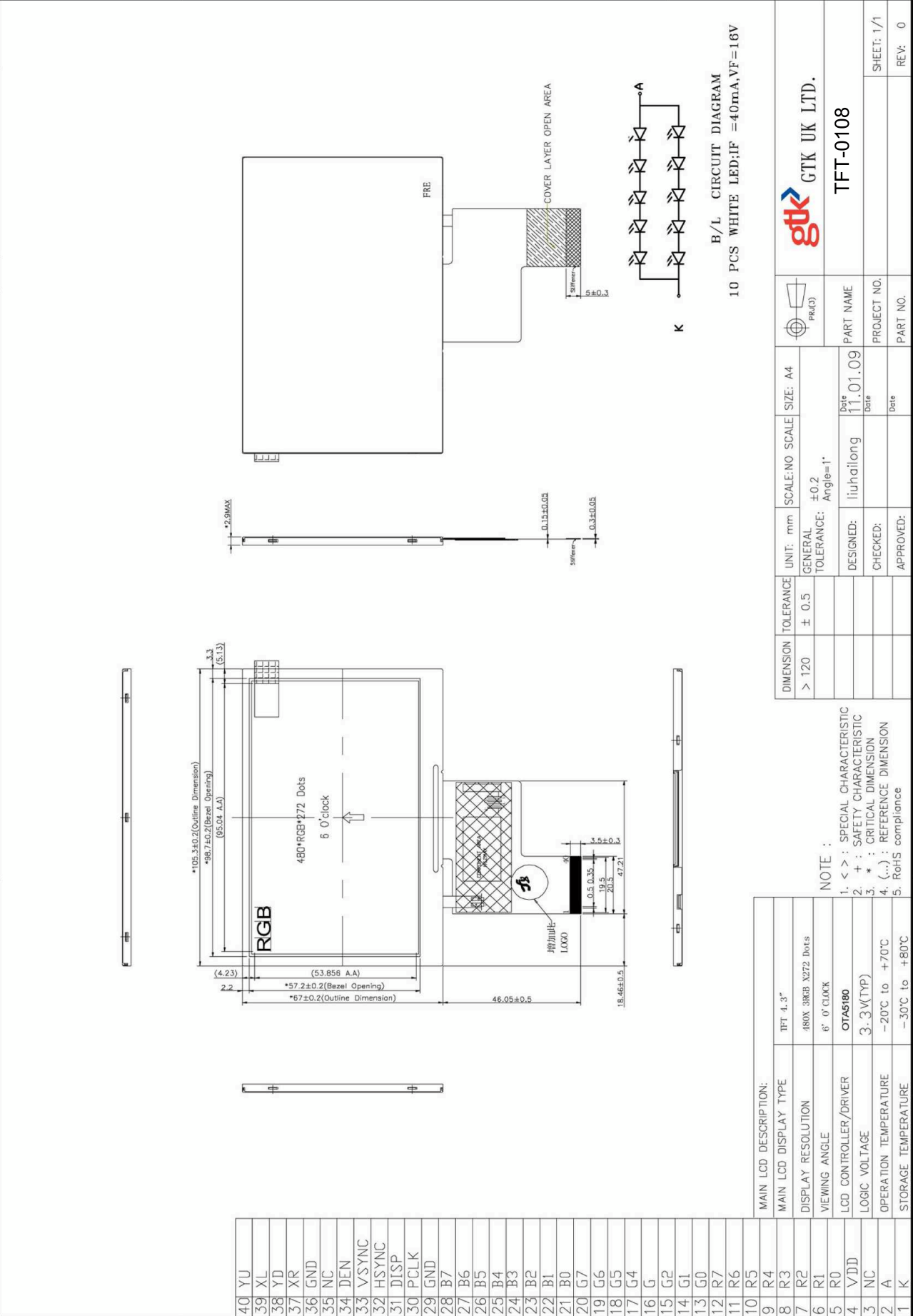

DIMENSION	TOLERANCE	UNIT	SCALE: NO	SCALE: SIZE
> 120	± 0.5	mm	A4	A4
GENERAL TOLERANCE: Angle=1°		± 0.2		
DESIGNED:	liuhailong	Date:	11.01.09	PART NAME
CHECKED:		Date:		PROJECT NO.
APPROVED:		Date:		PART NO.

MAIN LCD DESCRIPTION:		IFT 4.3"
MAIN LCD DISPLAY TYPE	480X 320X 322 Dots	
DISPLAY RESOLUTION	6" O'CLOCK	
VIEWING ANGLE	OTAS180	
LCD CONTROLLER/DRIVER	3-3V(TYP)	
LOGIC VOLTAGE	-20°C to +70°C	
OPERATION TEMPERATURE	-30°C to +80°C	
STORAGE TEMPERATURE		

NOTE :	
1. < > :	SPECIAL CHARACTERISTIC
2. + :	SAFETY CHARACTERISTIC
3. * :	CRITICAL DIMENSION
4. (..):	REFERENCE DIMENSION
5.	RoHS compliance

gtek		GTEK UK LTD.
TFT-0108		
SHEET: 1/1		REV: 0

1 2 3 4 5 6

5. ELECTRICAL CHARACTERISTICS:

DC CHARACTERISTICS

Parameter	Symbol	Min	TYP	Max	Unit
Supply voltage	VCC-VSS	2.7	3.3	3.6	V
Input Current	I _{dd}		TBD	TBD	mA
Input voltage H level	V _{IH}	0.8V _{cc}	V _{cc}	V _{cc}	V
Input voltage L level	V _{IL}	0	0	0.2V _{cc}	V
Output voltage H level	V _{OH}	0.8V _{cc}	V _{cc}	V _{cc}	V
Output voltage L level	V _{OL}	0	0	0.2V _{cc}	V

Backlight CHARACTERISTICS (I_F = 15mA)

Parameter	Symbol	Min	TYP	Max	Unit
Forward voltage	V _f	-	16.	-	V
Luminance(white display)	L _v	-	450	-	Cd/m ²
Brightness uniformity(white display)	B _u	80			%
Number of LED			10		piece
Connection mode			5Series/2parallel connection		

6. ABSOLUTE MAXIMUM RATINGS:

Parameter	Symbol	Min	Max	Unit
Supply voltage	VCC	-0.3	3.3	V
Input	V _{in}	-0.3	V _{cc} +0.3	V
Operating temperature	T _{op}	-20	70	°C
Storage temperature	T _{st}	-30	80	°C
Humidity	RH	-	90%(Max60°C)	Dot
Backlight Current	I _{BL}	-	40	mA(each Led)
Backlight Life		20000		hours

7. Timing Characteristics

Parallel RGB Data Format

Parallel RGB Input Timing Table

Item	Symbol	Min.	Typ.	Max.	Unit		
DCLK Frequency	Fclk	5	9	12	MHz		
DCLK Period	Tclk	83	110	200	ns		
Hsync	Period Time	Th	490	531	605	DCLK	
	Display Period	Thdisp		480		DCLK	
	Back Porch	Thbp	8	43		DCLK	By H_BLANKING setting
	Front Porch	Thfp	2	8		DCLK	
	Pulse Width	Thw	1			DCLK	
Vsync	Period Time	Tv	275	288	335	H	
	Display Period	Tvdisp		272		H	
	Back Porch	Tvbp	2	12		H	By V_BLANKING setting
	Front Porch	Tvfp	1	4		H	
	Pulse Width	Tvw	1	10		H	

SYNC Mode Timing Diagram

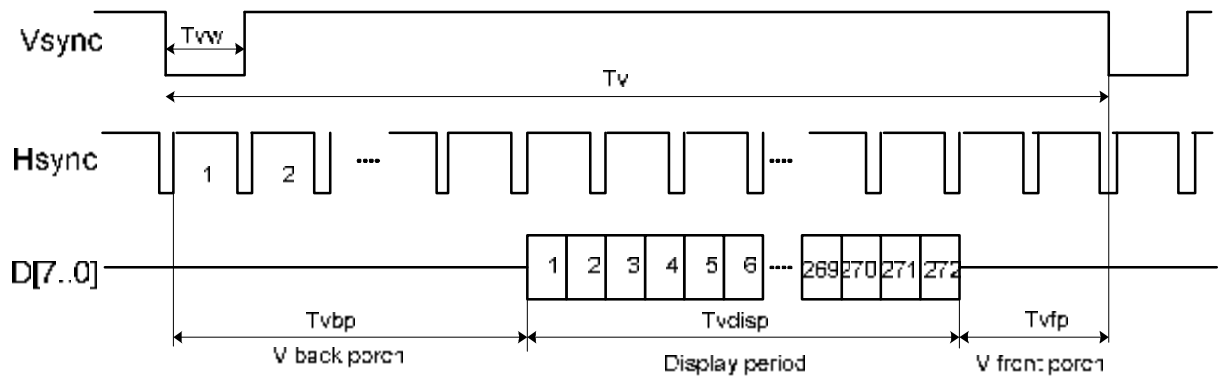
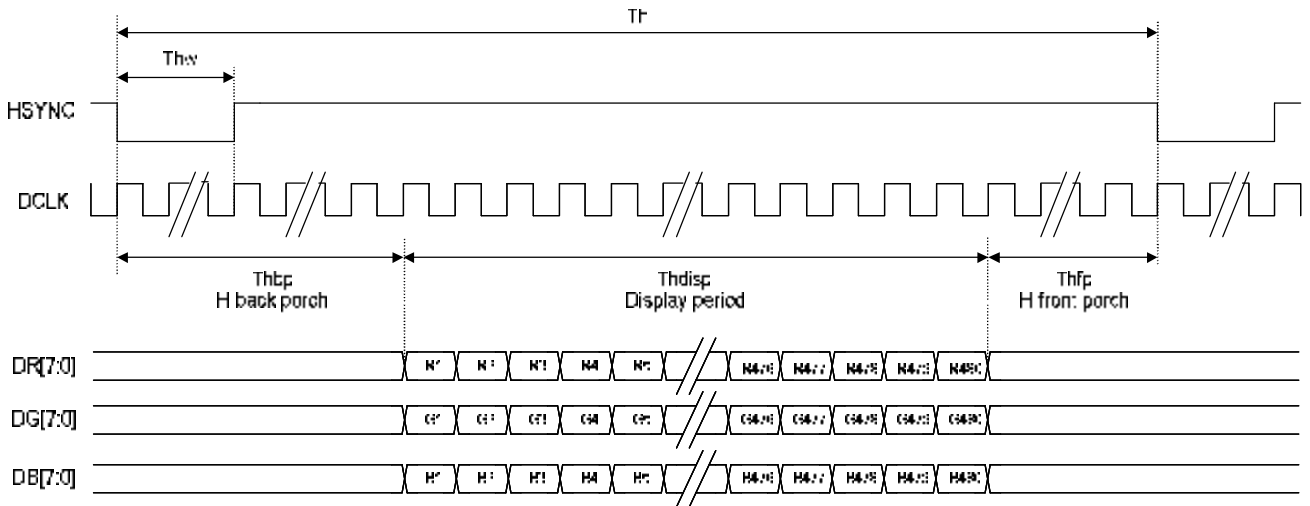

SYNC-DE Mode Timing Diagram

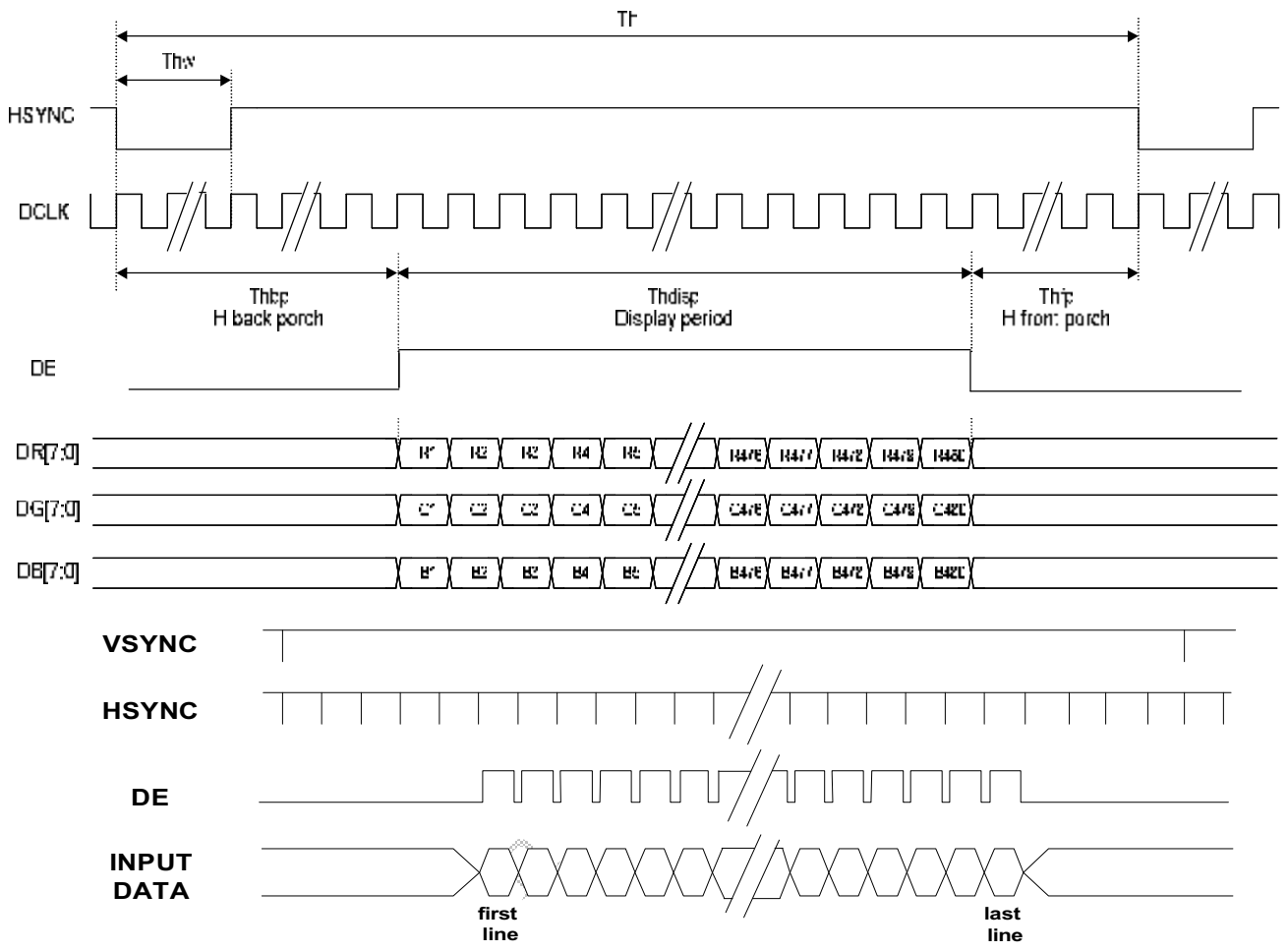

Power On Sequence

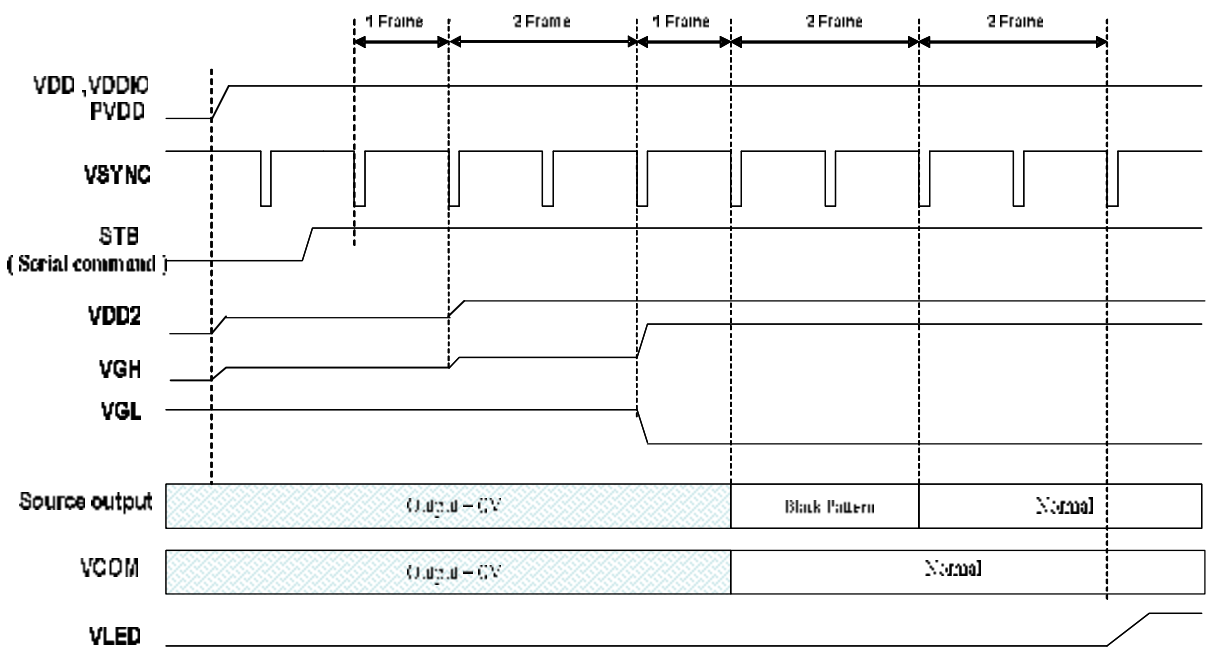

8. Electro-Optical characteristics .

Optical characteristics are determined after the unit has been 'ON' and stable for approximately 30 minutes in a dark environment at 25°C. The values specified are at an approximate distance 50cm from the TFT-LCD surface at a viewing angle of Φ and θ equal to 0° .

Measurement condition: Refer to next pages (C-light source, Halogen Lamp)

(Ta=25 ±2°C,VDD=2.8V,IB=15mA)

Item	Symbol	Condition	Min	Typ	Max	Unit	
Contrast ratio (Center point)	C/R	Note1 B/L On	250	350	-	-	
Response Time	Rising: Tr		Tr+ Tf	-	30	45	ms
	Falling:Tf						
Color Chromaticity (CIE 1931)	White		Wx	0.287	0.307	0.327	-
			Wy	0.325	0.345	0.365	
	Red		Rx	0.589	0.609	0.629	
			Ry	0.297	0.317	0.337	
	Green		Gx	0.297	0.317	0.337	
			Gy	0.523	0.543	0.563	
	Blue		Bx	0.117	0.137	0.157	
		By	0.141	0.161	0.181		
Viewing angle	Hor	θ L1	90	110	-	degree	
		θ R1			-		
	Ver	ϕ H1	110	130	-		
		ϕ L1			-		

Notes : 1. Contrast Ratio(CR) is defined mathematically as :

$$\text{Contrast Ratio} = \frac{\text{Surface Luminance with all white pixels}}{\text{Surface Luminance with all black pixels}}$$

- Surface luminance is the center point across the TFT-LCD surface 500mm from the surface with all pixels displaying white. For more information see FIG 1.
- Response time is the time required for the display to transition from white to black(Rise Time, Tr) and from black to white(Falling Time, Tf). For additional information see FIG 3.
- Viewing angle is the angle at which the contrast ratio is greater than 10. The angles are determined for the horizontal or x axis and the vertical or y axis with respect to the z axis which is normal to the TFT-LCD surface. For more information see FIG 5.

FIG. 1 Optical Characteristic Measurement Equipment and Method

LCD-7000 System

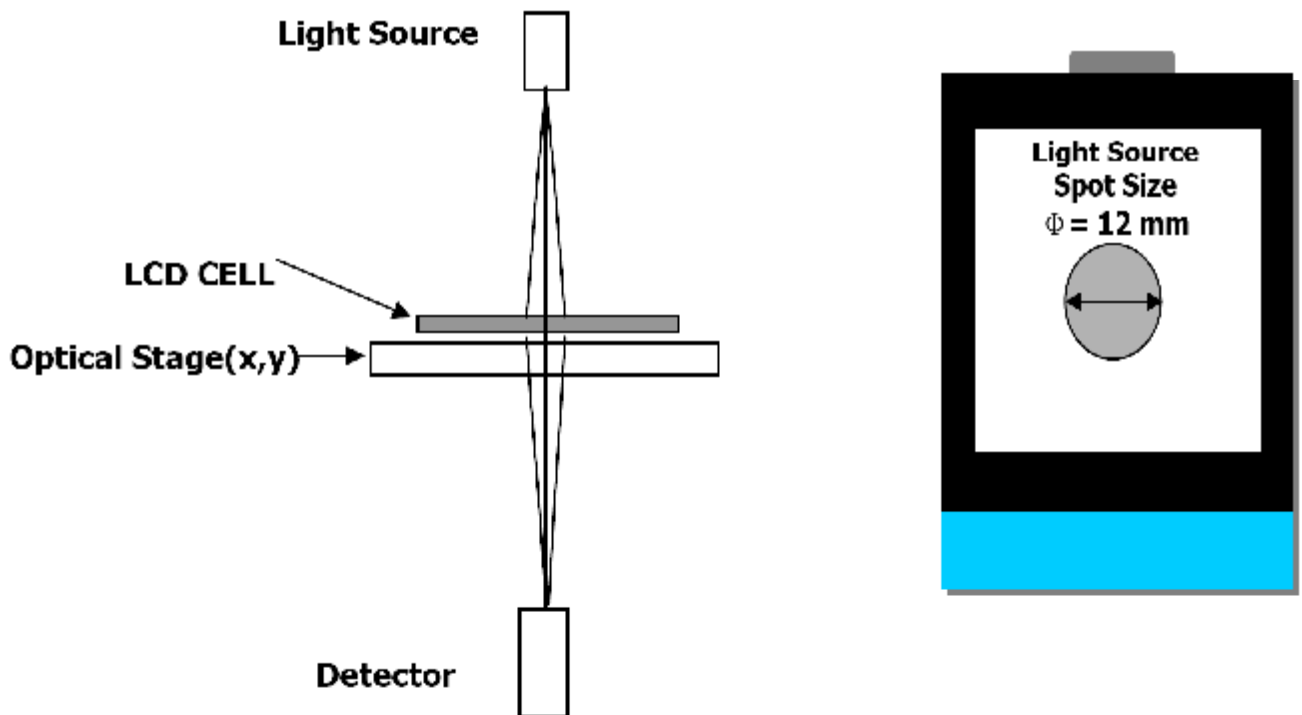

FIG. 2 The definition of V_{th} and V_{sat}

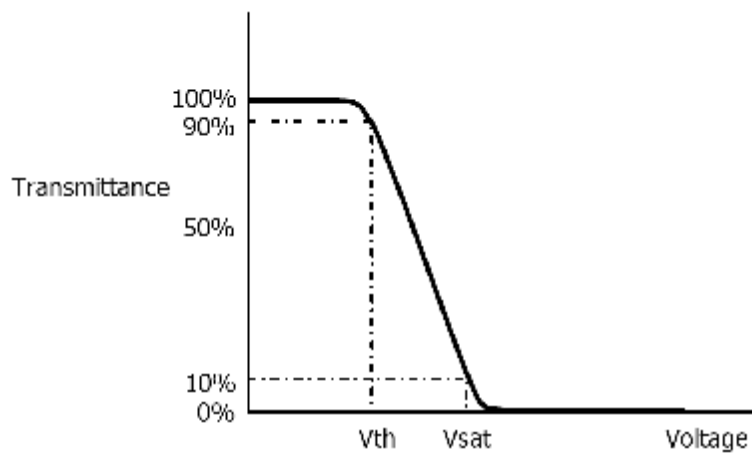
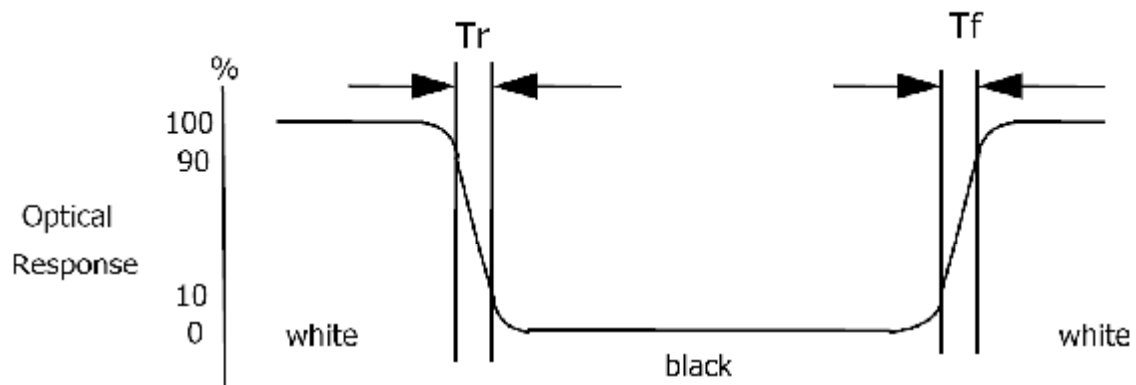

FIG. 3 The definition of Response Time

The response time is defined as the following figure and shall be measured by switching the input signal for "black" and "white".



* Voltage conditions for Response time

Vgate : 19V DC

Vdata : 0V~3.3V DC

Vcom : 0V (Ground)

FIG. 4 The definition of viewing angle

<dimension of viewing angle range>

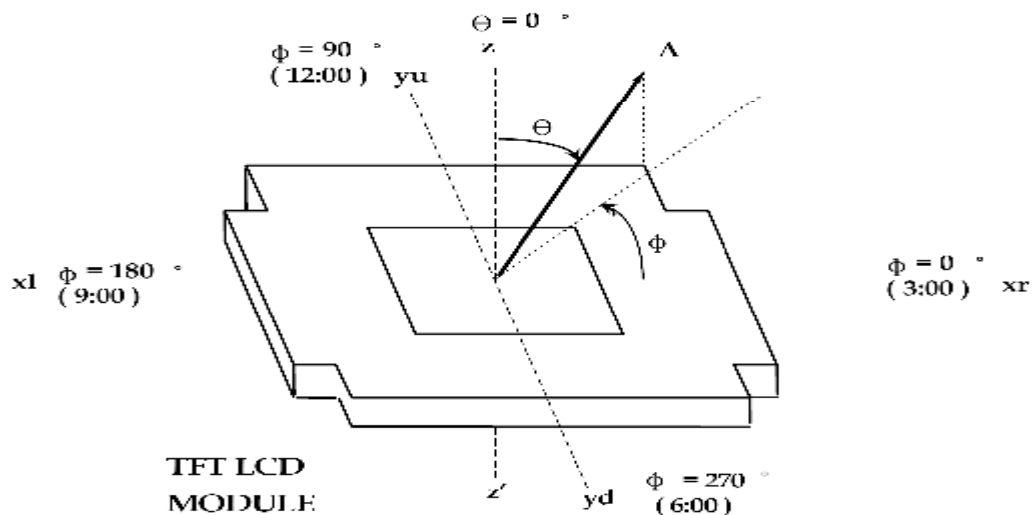

9. APPLICATION CIRCUIT

Please consult our technical department for detail information

10. INITIAL CODE

Pls consult our technical department for detail information

11. RELIABILITY TEST

11.1 Environment test

Test Item	Test Condition	Inspection after test
High Temperature Storage	80 °C 48hr	Inspection after 2~4hr storage at room temperature, the samples shall be free from defects: 1. Air bubble in the LCD 2. Sealleak. 3. Non-display 4. Glass crack 5. Missing segments; 6. Current Idd is twice higher than initial value. 7. Structure distortion
Low Temperature Storage	-30°C 48hr	
HighTemperature Operating	70°C 24 hr	
Low Temperature Operating	-20°C 24hr	
Temperature Cycle	-20°C → 25°C → 80°C → 25°C (30min) (5min) (30min) (5min) 20 cycles	
Damp Proof Test	50°C 90%RH / 120hr	
Vibration Test	Frequency: 55Hz Amplitude: 1.5mm~2.0 mm Z direction for total 3hr (Packing condition)	
Dropping Test	Drop to the ground from 1m height, one time , every side of carton (Packing condition)	
ESD Test	Voltage: ±6Kv / R:330 ohm /C:150pf /Air discharge,10time	

Remark:

1. The test samples is ok before test and should be applied to only one test item.
2. Sample qty for each test item is 3~5pcs.
3. For Damp Proof Test, pure water(resistance>10Mohm)should be used.
4. In case of malfunction defect caused by ESD damage, if it would be recovered to normal state after resetting, it would be judged as a good part. Using ionizer(an antistatic blower) is recommended at working area in order to reduce electro-static voltage. When removing protection film from LCM panel, peel off the tag slowly(recommended more than one second)while blowing with ionizer toward the peeling face to minimize ESD which may damage electrical circuit.
5. EL evaluation should be excepted from reliability test with humidity and temperature: Some defects such as black spot/blemish can happen by natural chemical reaction with humidity and fluorescence EL has.
6. Please use automatic switch menu or roll menu test mode when test operating mode.

11.2 Touch panel test (Only for with RTP LCM TFT-0012)

Test tool: pen tip R0.8mm & R8mm

Test Item	Test Condition	Judge standard
Hitting durability	300,000 times min at the same point Load: 150gf Hitting speed: 2times/sec Electric load: None	1) No glass break or glass crack after test 2) Resistance: X-axis: 200-900 ohm Y-axis: 200-900 ohm Insulation: >20M ohm
Pen sliding durability	50,000 times min Load: 150gf Sliding speed 2 times/sec Electric load: None	
Globule striking	Globule fall off once from 30cm height Globule is a steel globe and its diameter is 9mm Electric load: None	

11.3 Ultraviolet radiation irradiation test

After ultraviolet irradiation, samples have no deterioration of display quality.

12. Quality Guaranty

12.1 Manufacture assurance

Item		100% test	Sampling	Reliability test
Raw material			○	○
LCM finished goods	Electrical function	○	○	○
	Appearance	○	○	○
	Physical characteristics		○	○
	Environmental condition		○	○

12.2 Inspection environment condition

12.2.1 Temperature and humidity : Room temperature($23\pm 5^{\circ}\text{C}$) / less than 70%RH.

12.2.2 Vision inspection distance : 30cm at the upright direction

12.2.3 Inspection method :

12.2.3.1 The appearance inspection should be performed under a daylight lamp (Power of 40W/ Distance of 1.5m will be a standard at any disputation)

12.3.2.2 During the electrical functional test and the screen defect inspection , the LCD should light electrically and the environment light should be avoided with a lens hood or the test is performed under a dark condition

12.3 Sample plan : GB/T2828-03(II) AQL=1.0

12.4 Dimension measurement

11.4.1 Sample size : 5pcs per shipment lot

11.4.2 Criterion : Verify the important dimensions according to the appropriate drawing if needed and should reject the dimensions that are out of the tolerance.

12.5 Appearance inspection

12.5.1 General Parts:

Item	Criterion	Remark
1.FPCA	The criterion for chip component solder point: IPC-A-610C CLASS 2 on general occasion ◦	Vision Inspection / Microscope
2.Back light	2.1 Defect of no light is unaccepted ◦ 2.2 The brightness (test with BM-7 equipment) and power consume must meet SPEC	
3.Bezel	Any damage, distortion and other solder spark on the bezel surface is unaccepted ◦	
4.FPC	<p>4.1 Criterion for bending and crease As picture 22, "a" is the angle composed of the extended lines of the crease .This angle must be more than 90 degree.</p> <p>4.2 The area of crack, damage, foreign material and air bubble is not allowed to be more than 1/5 of that of the enhancing film ,</p> <p>4.3 Golden finger should not be scraped obviously; Any stain and foreign on the finger is unaccepted.</p>	Vision inspection / Microscope





Picture 22

5.LCD screen	<p>5.1 A protect plaster should be stuck to the screen based on the SPEC.</p> <p>5.2 Any dust, finger mark, stain or other foreign material on the screen surface which can not be got rid of with soft cloth or air gun is unaccepted.</p> <p>5.3 Defect of no display is unaccepted.</p> <p>5.4 Defect of lack of line or cross-talk is unaccepted.</p> <p>5.5 Abnormal chroma, brightness and contrast (compared with golden Sample and SPEC parameter) are unaccepted</p> <p>5.6 Uneven back light (compared with golden Sample) or dark area is unaccepted.</p> <p>5.7 Response time of menu change must meet SPEC.</p> <p>5.8The LCD screen shift amount should not be more than 0.2mm based on the SPEC.</p> <p>5.9The criterion should be loosened in judging of the defect in the area out of V.A.</p>	Vision inspection
--------------	---	-------------------

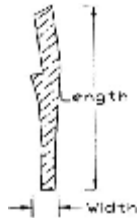
12.5.2 Cosmetic defects of LCM (Include Touch Panel and TFT) out of acceptable criteria are listed in below table

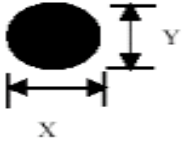
Inspection item	Criterion			Remark
Liner matter	Width (mm)	Length (mm)	Q'ty	
	$W \leq 0.1$	/	Ignore	
	$0.1 < W \leq 0.2$	$L \leq 5$	3	
	$W > 0.2$	/	0	
Scratch	Width (mm)	Length (mm)	Q'ty	As liner
	$W \leq 0.03$	/	Ignore	
	$0.03 < W \leq 0.05$	$L \leq 5$	2	
	$0.05 < W \leq 0.1$	$L \leq 2$	2	
	$W > 0.1 \text{mm or } L > 2 \text{mm}$		0	

Fish eye on film/ Dent on film and Air bubble	<table border="1"> <thead> <tr> <th>Size (mm)</th> <th>Q'ty</th> </tr> </thead> <tbody> <tr> <td>$D \leq 0.5$</td> <td>Ignore</td> </tr> <tr> <td>$0.5 < D < 1.0$</td> <td>2</td> </tr> <tr> <td>$D > 1.0$</td> <td>0</td> </tr> </tbody> </table>	Size (mm)	Q'ty	$D \leq 0.5$	Ignore	$0.5 < D < 1.0$	2	$D > 1.0$	0	Size : $D = (X+Y)/2$ 		
Size (mm)	Q'ty											
$D \leq 0.5$	Ignore											
$0.5 < D < 1.0$	2											
$D > 1.0$	0											
Dot	<table border="1"> <thead> <tr> <th>Size (mm)</th> <th>Q'ty</th> </tr> </thead> <tbody> <tr> <td>$D \leq 0.15$</td> <td>Ignore</td> </tr> <tr> <td>$0.15 < D \leq 0.25$</td> <td>2</td> </tr> <tr> <td>$0.25 < D \leq 0.35$</td> <td>1</td> </tr> <tr> <td>$D > 0.35$</td> <td>0</td> </tr> </tbody> </table>	Size (mm)	Q'ty	$D \leq 0.15$	Ignore	$0.15 < D \leq 0.25$	2	$0.25 < D \leq 0.35$	1	$D > 0.35$	0	As fish eye
Size (mm)	Q'ty											
$D \leq 0.15$	Ignore											
$0.15 < D \leq 0.25$	2											
$0.25 < D \leq 0.35$	1											
$D > 0.35$	0											
Newton's ring	<p>Rules</p>  <p>$\leq 1/3$ TP area</p> <p>irregular</p>  <p>Function OK</p>	As fish eye										

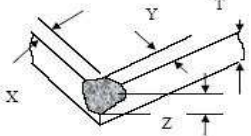
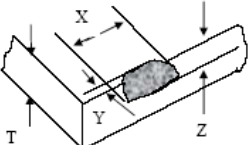
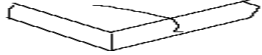

Chip and crack	Corner chip 	$X \leq 3\text{mm}$ $Y \leq 3\text{mm}$ $Z \leq T$
	General chip 	$X \leq 6\text{mm}$ $Y \leq 3\text{mm}$ $Z \leq T$
	Crack 	0

12.5.3 TFT Pixel Inspection

1) Pixel

b-pixels (R+G+B) 

2) DOT

1 sub-pixel (R or G or B /  or  or )

3) Bright/Dark Dot

A sub-pixel (R,G, B dot) stuck off/on (electrical)

Bright dots shall be counted on a black pattern and black dots on a pure R,G, B and white pattern.

4) Adjacent Dot

2 or 3 dots connected with neighboring dot. (R,G or G,B or B,R or R,G,B)

12.5.4 TFT Pixel Dot Defect Criteria

Defect Mode	Acceptable Judgment Criteria	
	Dot Type	Quantity (ea)
Bright Dot	Random (Red, Blue, Green)	1
	2 or more adjacent dot defects	0
Dark Dot	Dark dot	3
	2 adjacent dots	1
	3 or more adjacent dots	0

12.6 Function test

12.6.1 To set the voltage and current based on the specification requirement of the product make the LCD electrically light, then test LCD, the product will be accepted if its LCD can display normally.

12.6.2 The product should be judged as fail if there is any test item fails in passing the test.

12.6.3 If the product fails in test, it should be tested serially two times again, if it pass the testing in the last two times, then it should be accepted.

12.7 Accepted criterion : For a out going lot, We inspect it based on above sampling plan and the corresponding acceptable criterion, if all inspection items meet the SPEC , this lot should be accepted and rejected otherwise.

12.9 Package and storage

12.9.1 Placement

To handle lightly; to store in clear environment; to avoid direct daylight.

12.9.2 Cleaning method

Only soft cloth or equal material can be used to clean the screen gently. It is prohibited to use any stiff or other unproposed liquid to clean the screen. Especially below material is absolutely prohibited:

- Water
- Ketone
- Aromaticity compound

12.9.3 Package and storage method

- 1) Please place the product according to the method showed on the packing box.
- 2) All products should be handled and placed lightly avoiding any bump and knock, especially throw onto the earth.
- 3) Once the pack is opened, extreme temperature & humidity and dust should be avoided.
- 4) There must be Anti-ESD measure to protect the product during usage (the product include CMOS component)
- 5) All returned defective products should be rightly packaged with their original packing material and method.
- 6) To prevent modules from degradation, Do not operate or store them exposed direct to sunshine or high temperature/humidity

12.9.4 In case of storing for long period of time, the following ways are recommended:

- 1) Storage in polyethylene bag with opening sealed so fresh air outside can not enter in, and with no desiccant.
- 2) Placing in a dark place where neither exposure to direct sunlight nor light is keeping the storage temperature range.
- 3) Storing with no load on package surface by anything else.

13.0 General Precautions for touch panel

In order to prevent accidental use and performance deterioration, please keep the following precautions and inhibited points.

13.1. Transparency is an important factor for the product. So, please wear clean finger sacks, handling gloves and mask to protect the products from fingerprint or stain attach, and also hold the portion outside the view area when handling the panel.

13.2. Do not put a heavy, hard or sharp object on the product.

13.3. Wipe off the stain on the product by using soft cloth moistened with ethanol. Take care not to allow ethanol to soak into the joint of upper Film and bottom glass. Do not use

any organic solvent or detergent other than ethanol.

13.4. Do not clean with a thing other than the finger such as hard or sharp edges like a finger nail etc. on the cloth, because it cause transparent conductive film cracks. Please advise this inhibition to your last customers

13.5. Operate it with a polyacetal pen (tip R0.8 or over) or a belly of a finger without applying operation excessive load. Do not operate by other than polyacetal pen (tip R0.8 or over) and/or a belly of a finger like a hard or a sharp edges such as a ball point pen, sharp pencil, sharp tiptoe, etc. Operation at the out of Active Area is out of our guarantee. Because, it causes a serious damage of a transparent electrode. Do not operate at the out of Active Area.

13.6. Design guide -----important message, please read it carefully.

(1) Electrical aspect

1. Keep the voltage under DC 7V operating the T/P.
2. The Touch Panel cannot work correctly while touch two separate points at the same time.
3. The contact resistance need to be stabilized before read the position figure.
4. Please design the capacitor value of the touch panel in your sensing circuit and low-pass filters as it acts in an equivalent circuit.

(2) Software

It should be have the location calibration function in customer's software.

Please include "User calibration" in your software programming for long term using.

(3) Mechanical Design

Active Area

The linearity, durability, and the operating force is guaranteed inside this area.

1. Please design your function area inside the "Active Area", which is 1mm~1.5mm inside of the transparent insulation area.
2. Usually, the "Active Area" is equal or more than customer's display "Active Area".
3. Due to the construction and the material character, the durability of the input area at the edge is less than the center area; suggest not placing the key function at the edge area.

Unbearable Area

1. It still can be activated at this area, only the resistance is not stately, the linearity could not be guaranteed.
2. While in design, to prevent the potential problem is to avoid the housing of the unit to have any contact from the touch panel, or possible pressing on it while holding it. The contact causes the malfunction.

3. Normally, the durability is not guaranteed. The sliding in this area may cause the damage of the touch panel.
4. Usually the width of unbearable area is 1~1.5mm from “Active Area”, please check our specific drawing for each size, or discuss with our engineer.

Transparent Insulation-area

1. The Insulation area is located outside the “Active Area” with a distance of 1~1.5mm. Please see the attached drawing of cross-section construction. It is to prevent the malfunction of the housing edge contacting the touch panel.
2. We suggest your housing design at least keep. 1.0mm outside the inner edge of Transparent Area. Please see the attached drawing of cross-section construction.

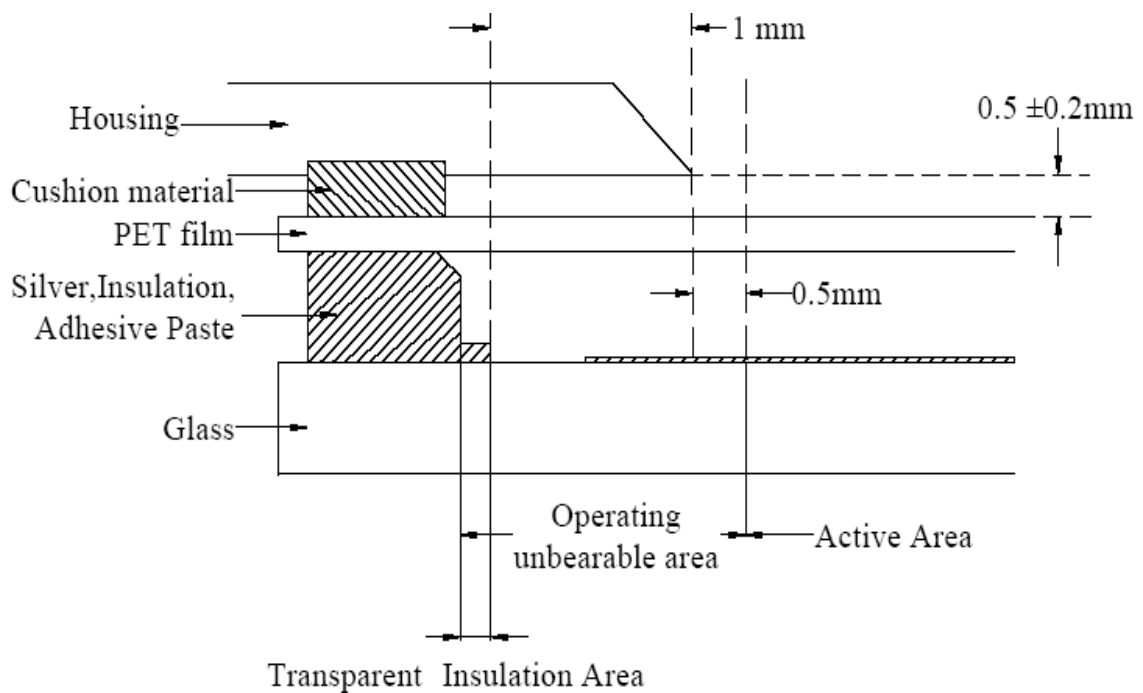

14.0 Other agreement