

REV	ZONE	REVISION	DATE

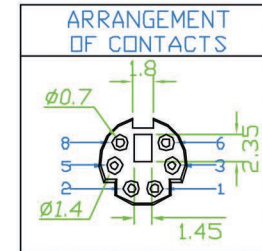
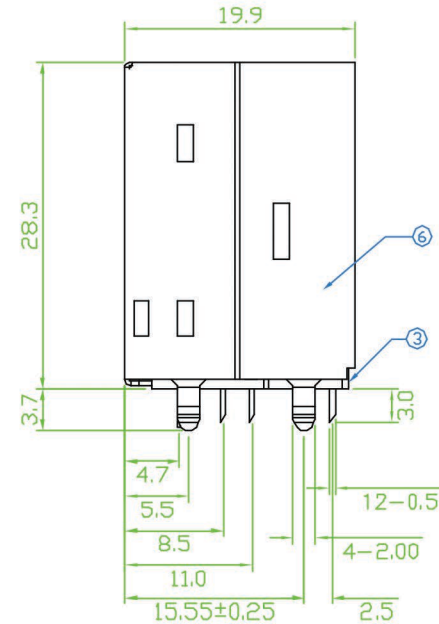
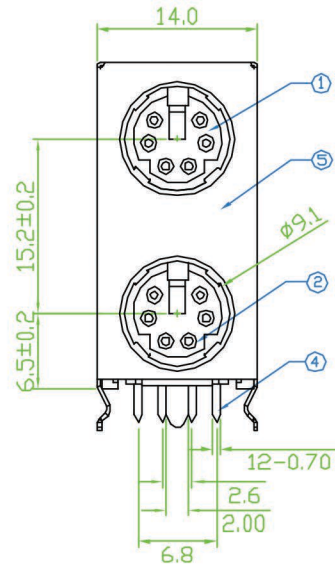

ROHS COMPLIANT

Specification:

- Contact Resistance: 30m Ohm Max.
- Insulation Resistance: 100M Ohm Min. AT 500V DC
- Rated Voltage And Current: DC 12V. 2A Max; AC 100V. 1A Max
- Dielectric Withstanding Voltage: 250V AC For 1 Minute
- Durability (Life Test): 100 Cycles
- Insertion Force: 4.0KG Maximum.
- Extraction Force: 0.9KG Minimum.

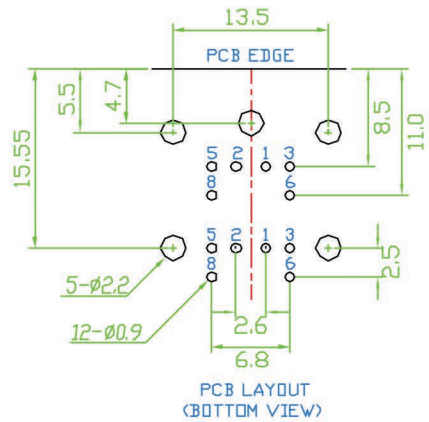

NO.	NAME	MATERIAL	FINISH	REMARK	Q'TY
1	TOP HOUSING	PBT G.F.	BLACK		1
2	BOTTOM HOUSING	PBT G.F.	BLACK		1
3	BACK COVER	PBT G.F.	BLACK		1
4	CONTACT TERM.	PHOS. BRONZE T:0.2	GOLD/TIN PLATED	Gold:1~3u"; NI:40~60u"; TIN:120u" (100% pure Tin of lead free plating)	12
5	FRONT SHIELD	BRASS T:0.3	TIN PLATED	TIN:120~200u"	1
6	BACK SHIELD	BRASS T:0.3	TIN PLATED	TIN:120~200u"	1



COMPUTER NO.		UNIT	SCALE	PART NAME		
		mm	1:1	MINI DIN JACK DUAL		
APPD.	CKD.	DWG.	DATE	TOLERANCE	PART NO.	REV.
		TINA	23-04-10	X. ±0.38 .X ±0.25 .XX ±0.13 .XXX ±0.05	DULM06FM06F-B-R	A3